



Modular Cooking Range Line thermaline 80 - 2 Zone Induction Top, 1 Side

ITEM # _____

MODEL # _____

NAME # _____

SIS # _____

AIA # _____



588019 (MAIBAADOAO) Induction top, 2 zones, one-side operated

Short Form Specification

Item No. _____

Unit constructed according to DIN 18860_2 with 20 mm drop nose top. Internal frame for heavy duty sturdiness in 2 mm and 3 mm in 1.4301 (AISI 304). 2 mm top in 1.4301 (AISI 304). Flat surface construction, easily cleanable. THERMODUL connection system enables seamless worktop when units are connected and avoids soil penetrating. Smooth glass ceramic surface without any "dead" spots allows for quick and easy cleaning. Features 9 power levels with fast deployment to full heating power and very low heat dissipation to the kitchen. Overheat protection switches off the supply in case of overheating. Metal knobs with embedded hygienic silicon "soft" grip enable easier handling and cleaning.

IPX5 water resistance certification.

Configuration: One-side operated top. The base needs to be supplied by the factory. Please include appropriate base.

Main Features

- Fast deployment with full heating power immediately.
- Low heat dissipation to the kitchen.
- Overheat protection: a temperature sensor switches off the supply in case of overheating.
- Pans can easily be moved from one area to another without lifting.
- The smooth glass-ceramic surface can be quickly and easily cleaned, thus providing maximum hygiene.
- All major components may be easily accessed from the front.
- THERMODUL connection system creates a seamless work top when units are connected to each other thus avoiding soil penetrating vital components and facilitating the removal of units in case of replacement or service.
- Metal knobs with embedded hygienic "soft-touch" grip for easier handling and cleaning. The special design of the controls prevents infiltration of liquids or soil into vital components.
- 9 power levels.
- Large visible digital display manufactured in tempered glass to resist heat and chemicals, showing temperatures or power settings. The display also shows on/off status of the appliance and on/off status of the heating elements.

Construction

- Control light for each zone.
- 2 mm top in 1.4301 (AISI 304).
- Flat surface construction with minimal hidden areas to easily clean all surfaces
- Internal frame for heavy duty sturdiness in 1.4301 (AISI 304).
- Unit constructed according to DIN 18860_2 with 20 mm drop nose top.
- Unit constructed according to DIN 18860_2 with 20 mm drop nose top and 70 mm recessed plinth.
- IPX5 water resistance certification.

Sustainability



- This model is compliant with Swiss Energy Efficiency Ordinance (730.02).

Optional Accessories

- Scraper for cook tops PNC 910601
- Connecting rail kit, 800mm PNC 912500
- Connecting rail kit, right PNC 912971
- Connecting rail kit, left PNC 912972

APPROVAL: _____



- Endrail kit, flush-fitting, left PNC 913109
- Endrail kit, flush-fitting, right PNC 913110
- Endrail kit (12mm) for thermaline 80 units, left PNC 913200
- Endrail kit (12mm) for thermaline 80 units, right PNC 913201
- INSERT.PROFILE,D800,TL-OTHER BRANDS PNC 913230
- - NOT TRANSLATED - PNC 913249
- - NOT TRANSLATED - PNC 913250
- - NOT TRANSLATED - PNC 913253
- - NOT TRANSLATED - PNC 913254
- FILTER W=400MM PNC 913663
- ELECTRIC MAINSWITCH 25A 4mm² NM FOR MODULAR H800 ELECTRIC UNITS (FACTORY FITTED) PNC 913676

Front

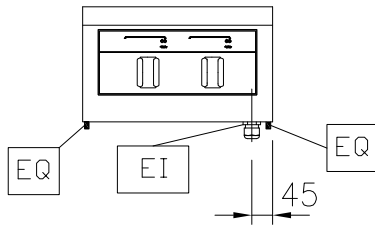

Side

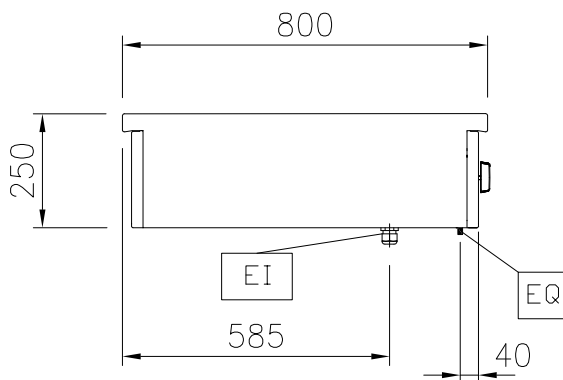

EI = Electrical inlet (power)
 EQ = Equipotential screw

Top

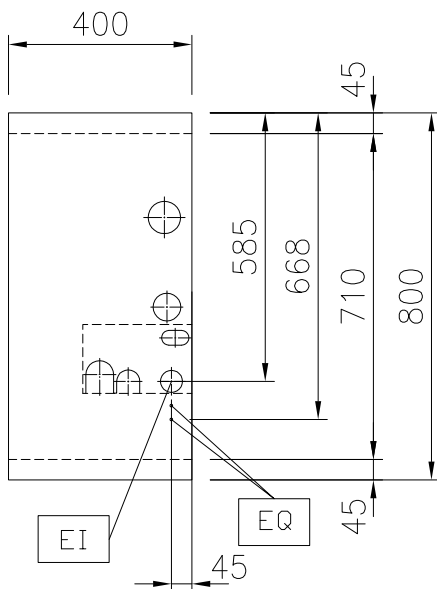

Electric

Supply voltage: 400 V/3N ph/50/60 Hz
 Total Watts: 10 kW

Key Information:

External dimensions, Width: 400 mm
 External dimensions, Depth: 800 mm
 External dimensions, Height: 250 mm
 Net weight: 22 kg
 Configuration: One-Side Operated;Top
 Front Plates Power: 5 - 0 kW
 Back Plates Power: 5 - kW
 Front Plates dimensions: 320x330
 Back Plates dimensions: 320x330
 Induction Top Dimensions (width): 400 mm
 Induction Top Dimensions (depth): 800 mm

Sustainability

Current consumption: 15 Amps



Optional Accessories

- Scraper for cook tops PNC 910601
- Connecting rail kit, 800mm PNC 912500
- Connecting rail kit, right PNC 912971
- Connecting rail kit, left PNC 912972
- Endrail kit, flush-fitting, left PNC 913109
- Endrail kit, flush-fitting, right PNC 913110
- Endrail kit (12mm) for thermaline 80 units, left PNC 913200
- Endrail kit (12mm) for thermaline 80 units, right PNC 913201
- INSERT.PROFILE,D800,TL-OTHER BRANDS PNC 913230
- - NOT TRANSLATED - PNC 913249
- - NOT TRANSLATED - PNC 913250
- - NOT TRANSLATED - PNC 913253
- - NOT TRANSLATED - PNC 913254
- FILTER W=400MM PNC 913663
- ELECTRIC MAINSWITCH 25A 4mm² NM FOR MODULAR H800 ELECTRIC UNITS (FACTORY FITTED) PNC 913676

